

# User Manual



**AutoGen X smart controller**

# Table of Contents

## **ABOUT THIS MANUAL**

- Purpose
- Scope
- Safety Instructions

## **INTRODUCTION**

- Features
- Basic System Architecture
- Product Overview

## **INSTALLATION**

- Unpacking and inspection
- Preparation
- Mounting the unit
- Power connection
- Connecting to the internet
- Relays
- Actuators
- Engine/generator running signal
- Battery bank sensing
- External start/stop

## **REMOTE MONITORING**

- AutoGen app installation
- Account setup
- App Features

## **OPERATION**

- Power on the controller
- Initial AutoGen app settings
- Operating modes description
- Starting generator remotely
- Stopping generator remotely
- Automated startup and shutdown
- Externally triggered startup and shutdown
- Faults reference codes
- Warning indicators and notifications

## **SPECIFICATIONS**

- Power input
- Generator running signal input
- Relay outputs
- Battery bank sensing input

## **TROUBLESHOOTING**

- Relay connections
- Generator running signal
- Internet connectivity
- AutoGen app connectivity

### **Appendix I: OTA (over the air) updates**

### **Appendix II: N/A**

## ABOUT THIS MANUAL

### Purpose

This manual describes the assembly installation operation and troubleshooting of this unit. Please read this manual carefully before installations and operations. Keep this manual for future reference.

### Scope

This manual provides safety and installation guidelines as well as information on tools and wiring.

### Safety instructions

Warning: this chapter contains important safety and operating instructions. Read and keep this manual for future reference.

1. Before using the unit, read all instructions, study the wiring diagram and all appropriate sections of this manual.
2. **Caution** - To reduce the risk of injury to yourself or any person, property or equipment It is advised to have good knowledge of electrical connections. If you are uncertain it is advised to seek professional assistance.
3. For optimum operation of this controller, please follow required spec to select appropriate cable sizes, relays and all other electrical connections.
4. Be very cautious when working with metal tools on or around batteries. A potential risk exists to drop a tool to spark or short circuit batteries or other electrical parts and could cause an explosion.
5. Strictly follow installation procedure when you want to disconnect AC or DC terminals. Please refer to **installation** section of this manual for the details.
6. This unit has no reverse polarity protection. Never connect power input to AC. All **ground/GND** references in this manual refer to negative side of battery.
7. **Warning** - This unit is not waterproof. If exposed to water or high humidity, internal damage to the circuitry will occur. In such a case of exposure to external elements, it is advised to use a waterproof enclosure.

## INTRODUCTION

### Features

- Automatic start and stop of any electrical start generator or engine.
- Remote control and monitoring from any location.
- Configurable settings within AutoGen app or hard coded from factory.
- Automated modes with or without Internet connectivity.
- Built in Wi-Fi with the addition of LoRa (depending on model).
- Configurable start up when sensing a battery bank.
- Configurable shutdown when sensing a battery bank.
- Multiple generator running signals, selectable within AutoGen app.
- Automated choke operation of petrol/gas engines(choke actuator required).
- Selectable day of week, time zone, Start Stop timer.
- History graph.
- E-mail notifications if failed startup attempts.
- External startup and shutdown trigger from a dry contact relay.
- Engine runtime.
- Reports can be exported in CSV file format.
- Temperature sensing(sensor required).
- DC current sensing(sensor required).
- OTA(over the air) updates.
- Customizable settings upon request.

### Basic system architecture

The following illustration shows basic application for this unit.

Consult with our support team for other possible system architectures depending on your requirements.

### Product overview

1. Wi-Fi or LoRa antenna
2. 12vac or 110/220vac L and N output as generator running signal
3. Power input
4. Relay control
5. Input voltage sensing
6. 12vdc charge circuit as generator running signal
7. Status LED
8. Unique QR code and serial number

## **Unpacking and inspection**

Before installation, please inspect unit. Be sure that nothing inside the package is damaged. You should have received the following items inside of package.

## **Preparation**

Basic tools are needed. A multimeter would be of great assistance. Before connecting all wiring, study our wiring diagram. Source your generator wiring diagram as well. This will assist you throughout the installation process.

## **Mounting the unit**

Consider the following points before selecting way to install:

- Never mount controller on any hot surfaces.
- Never mount controller in an area where it will be exposed to extreme weather conditions.
- The ambient temperature should be between -15degrees Celsius and 55degrees Celsius.

## **Power connection**

Pins 1 and 2 are for powering the controller. You may power the controller from the generator starter battery or an external 12 Volt DC power source. It is common practice to always have that generator starter battery on a maintenance or trickle charger. This will serve as powering the unit and always keeping the battery on float charge.

**Important note:**

Never apply positive power to the ground terminal pin 2, as this will permanently damage the unit. There is no reverse polarity protection.

## **Connecting to the Internet**

The controller is shipped with preconfigured wifi credentials SSID and password. SSID is **AutoGen** and password is **12345678**

You may set up a mobile hotspot with name **AutoGen** and password **12345678**

The controller will automatically connect to the hotspot as the credentials are already stored.

To connect the controller to your wifi access point, you will need to run SmartConfig setup available for iOS and Android devices.

When the controller is powered, press the Reset button.

During initial boot up, observe the status led.

If it cant connect with the stored credentials, after a few seconds it will automatically enter SmartConfig mode for 60 seconds and led will turn Magenta. At this point, run the SmartConfig mobile application.

Your phone must be connected to same wifi router you want the AutoGen controller to connect to.

**Please follow ESP SmartConfig setup instructions available at [www.dcautogen.com/downloads/](http://www.dcautogen.com/downloads/)**

## Relays

Observing the wiring diagram you will see three relay output pins #5, #8 and #9.

Pin#5 is used for the Choke Linear Actuator or as an auxiliary, pin#8 for stopping the generator and pin#9 for starting the generator.

These pins ground the relay coil when activated, therefore energizing the relay. The wiring diagram depicts commonly used 12vdc automotive style relays. These can be 4 leg Normally Open(87) and Common(30) or 5 leg Normally Closed(87a), Normally Open(87) and Common(30).

Common and Normally Open legs are to be connected to your generators stop and start circuits.

Let's see some examples below:

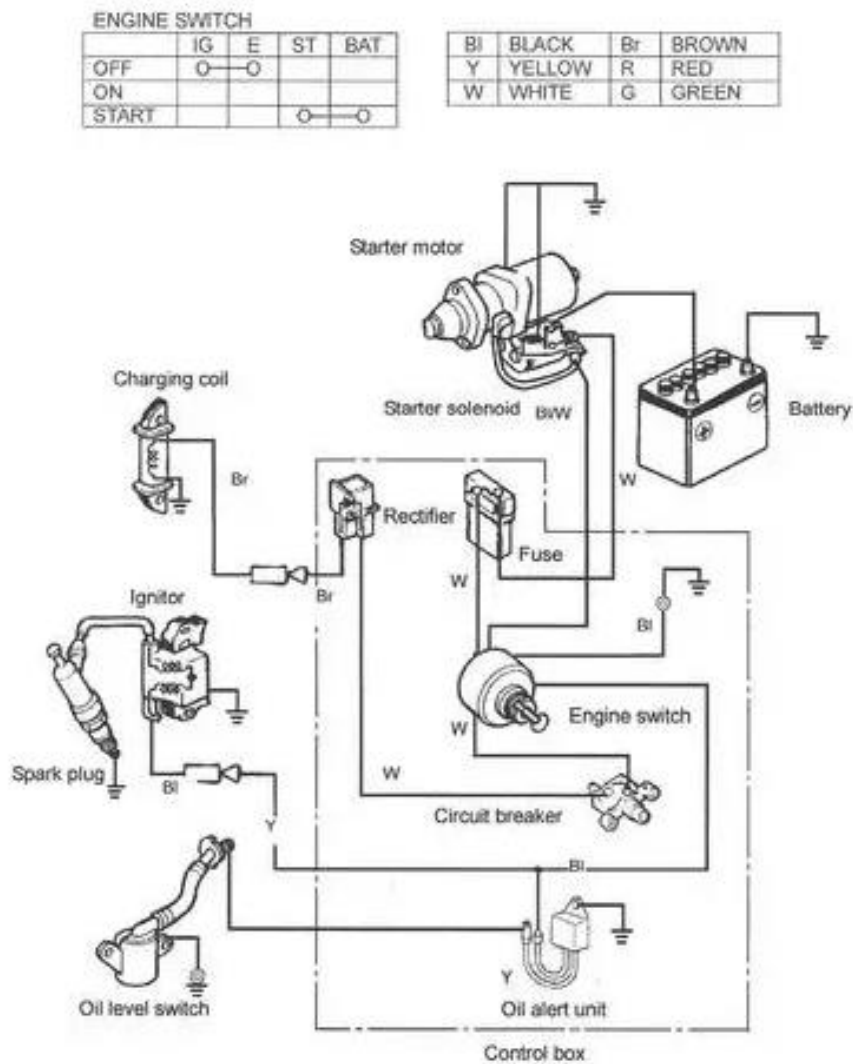



Here we can see that the engine switch contacts IG and E are closed to shut down the engine and ST and BAT are closed to start the engine.

We will need to connect IG to 87 and E to 30 of Stop relay.

To start the engine we need to connect ST to 87 and BAT to 30 of Start relay.

You can make a parallel connection to your existing generators wiring by tapping into the existing wires. This way you can still use the generators engine switch.

Keep note that the engine switch must remain in the ON or RUN position.

Let's see a similar example below:

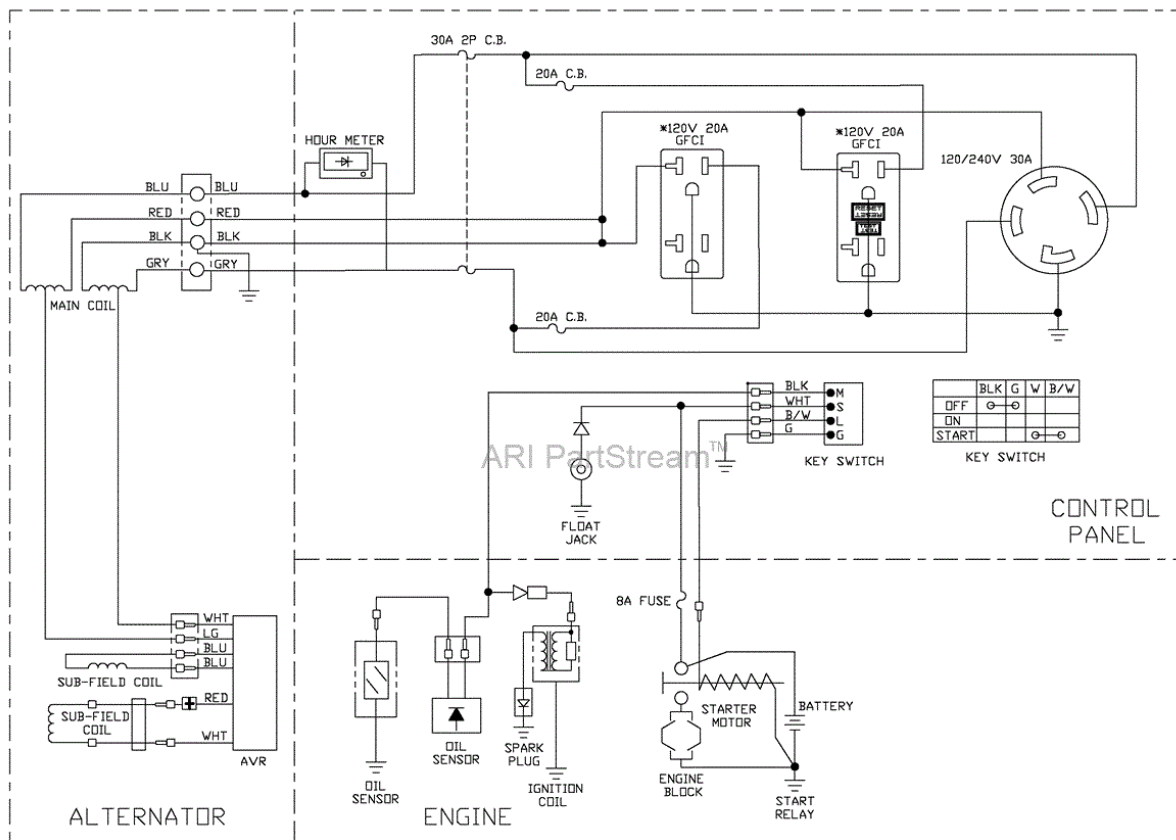

\* CONNECTION OF LINE AND LOAD POINTS ON GFCI RECEPTACLE SHOWN MAY NOT REPLICATE ACTUAL GFCI RECEPTACLE USED. REFER TO ACTUAL GFCI RECEPTACLE USED FOR PROPER CONNECTION OF LINE AND LOAD POINTS.

Here we can see that the key switch contacts BLK and G are closed to shut down the engine and W and B/W are closed to start the engine.

We will need to connect BLK to 87 and G to 30 of Stop relay.

To start the engine we need to connect W to 87 and B/W to 30 of Start relay.

Here is a more complicated ignition switch:

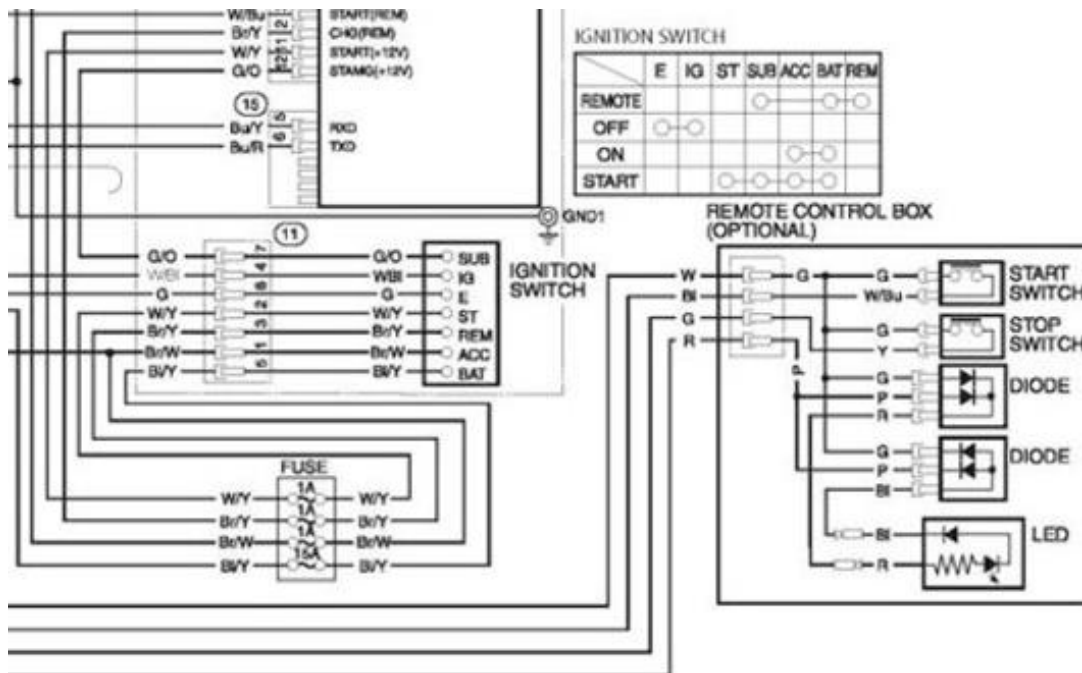

In this case we need to use 3 relays.

1 for Stop

1 for On

2 for Start

Let's break it down:

E and IG to 87 and 30 of Stop relay

ACC and BAT to Aux relay

ST and SUB to Start relay.

We would need to alter the operating sequence of the ON position to use the AUX relay. This can be done via a quick OTA update post sale or prior to shipping upon request.

By default pin#5 AUX is programmed to operate a choke linear actuator. We would need to have this pin output active, during Crank and Run condition of generator.

If in doubt just contact our support team for assistance.

## Actuators

Almost all gas/petrol small engine generators on the market, require choke to start. The choke maybe manually operated or electronically operated via a stepper motor.

If manually operated, we would need to automate this process with our choke linear actuator.

Let's see the wiring diagram below:

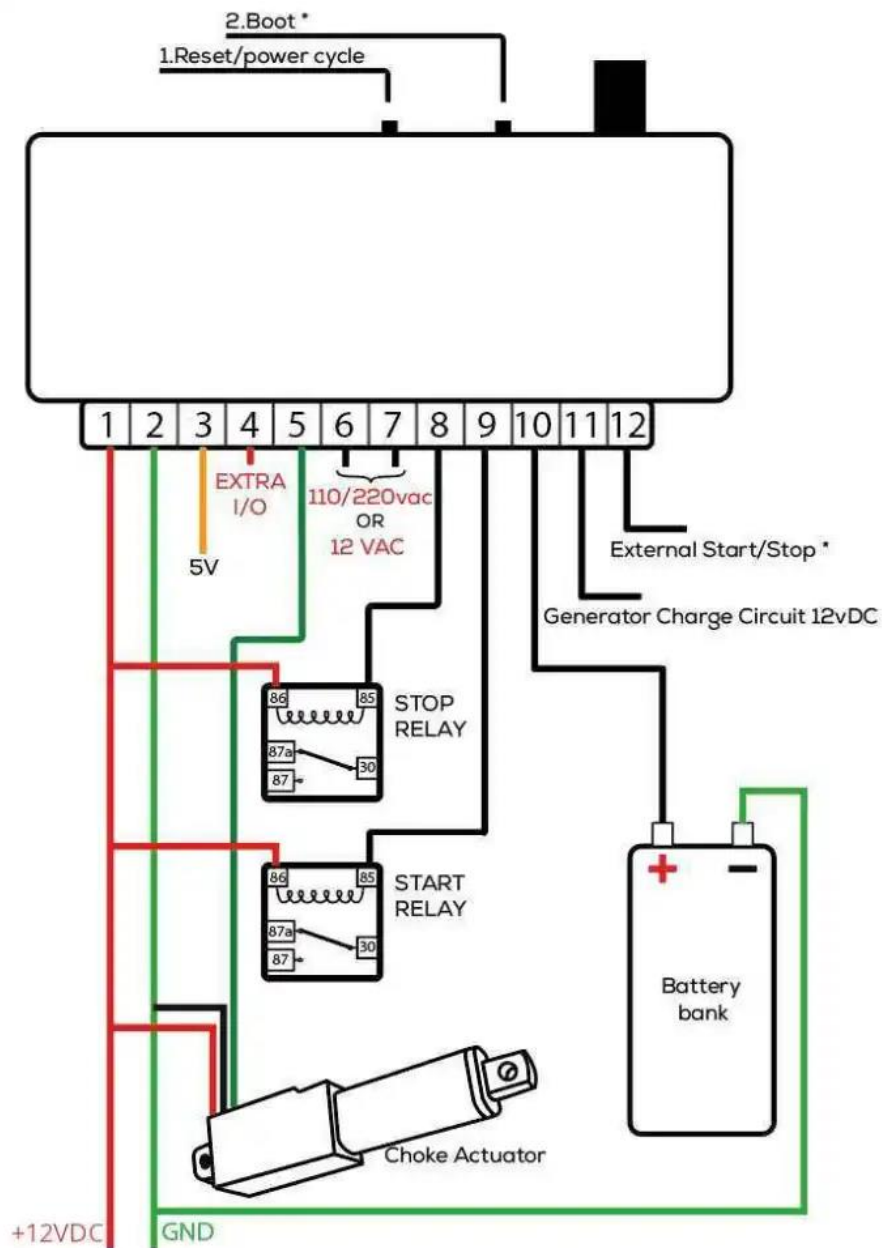

External Start/Stop : +12v generator will start and 0v will shutdown  
 2.Boot : (hold 3 seconds for OTA update or 10 seconds for clear stored wifi credentials)

The actuator is prewired with a DPDT(double pole double throw) relay. Red wire is connected to constant +12vdc, Black wire is connected to GND and the Green wire is connected to pin#5.

By default, the operating sequence is as follows:

1<sup>st</sup> startup attempt, the Choke is activated and extends its linear motion while the starter motor is cranking the engine. If startup is successful, It will with track to its original position.

If the startup process is unsuccessful the 1<sup>st</sup> time, the actuator will remain inactive for attempts 2 and 3. The purpose is to not flood the engine with excess fuel.

## **Engine/generator running signal**

This signal is crucial for the correct operation of the controller.

When the controller is cranking the engine, it needs to sense this signal as to know when the engine has successfully started up and is running. This signal is also used to notify, if the engine was shut down when not requested by controller. Either through the lack of fuel or a mechanical failure.

Two options are available:

Pin#6(L) and pin#7(N) input connections to sense the generators 110/220vac output or 12vac output from charging coil(prior to rectification) , or

Pin#11 to sense +12vdc from the engines charging circuit.

The available option needs to be selected within the app.

Note: pin#11 must ONLY sense 12vdc when engine is running. Do not connect directly to starter battery. Most generators have a 12v - 8amp battery charging port available. Connect pin#11 to the positive of this port.

## **Batter bank sensing**

AutoGen controller can monitor a battery bank via pin#10. You can set a low battery bank threshold within the app to start the generator. There is also a high cut off threshold to shut down the generator if it has been reached.

You can monitor the battery bank reading within the app.

If the reading is inaccurate this could be due to voltage drop. There is a calibration slider located at the bottom of the MAIN UI within the app. Adjust the slider accordingly to match as close as possible the app's reading, with the voltage at the battery terminal via a multimeter.

Pin#10 has a maximum input tolerance of 70vdc. It can be used to monitor any 12v, 24v or 48v bank.

## **External start/stop**

You can signal the generator to start/stop from any external source via pin#12.

This can be an ATS, inverter/charger, digital timer, toggle switch, float switch etc.

By default this input pin is used to sense a +12vdc signal to start the generator and 0v to shut down. It runs different logic within the controllers programming and is displayed in app as 2 Wire mode.

When the pin senses +12vdc, it will trigger an auto start. The 12v must remain active for the generator to run. If for any reason the engine has shut down while the pin is still active, it will enter a 2 Wire Error state. This is to ensure that we receive an email notification that the generator was shutdown(lack of fuel etc), even though we still need it to be running. When 2 Wire mode has been initiated, it must be shutdown by 0v on pin#12.

## **REMOTE MONITORING**

### **AutoGen app installation**

App is available for Android and iOS devices.

Links are available at [www.dcautogen.com/downloads/](http://www.dcautogen.com/downloads/)

To be able to monitor your generator from any location, the controller must be connected to the Internet.

### **Account setup**

You need to set up a user account and scan the unique QR code provided when purchased. The QR code can only be scanned once per new user created for security purposes. Please make sure you save your user credentials to avoid disconnection from your controller.

**Note:** Deletion of your user account will unlink your account from the specific controller. You would need a new QR code and the controller will also need to be updated to regain access. You can monitor from multiple devices with the same user account credentials.

## App features

### MAIN UI screen

- LCD widget which displays the various controller modes.
- You can also view the battery bank, generator running signal and amperage when using a current sensor.
- Start and stop buttons to remotely control the generator from any location.
- Status LEDs for generator running, float (when using current sensing), high cutoff voltage reached, timer active and error.
- History graph showing battery bank voltage, generator charge circuit (aka running signal), amps and temperature. You can select different intervals at the bottom of the history graph widget.
- Daily timer is depreciated and only active for older models.
- Quiet timer when you don't want the generator to run.
- Below are three, preconfigured timers. You would need to start the generator then press one of the timers to activate it. Generator will shut down when the time has been reached.
- The terminal widget can give you a lot of information regarding the controller, like serial number, firmware version, wifi ip address, LoRa connection status, sensor readings etc.
- Battery bank calibration slider that can be used to compensate for any voltage drop between your controller and the battery bank.

### AutoGen Settings tab

- Battery bank low set voltage. If your bank voltage is equal or lower than that setting, generator will start.
- High battery bank shut off voltage. If your bank voltage is equal or higher than that setting, generator will shut down.

- Setting to set your appropriate generator running signal.
- AutoGen X – running signal adjustment. This voltage setting will determine at which voltage and above the controller should use as running status.
- The rest on this tab are for V5 AutoGen 48v DC Generators.

### **Temperature settings.**

- Only Applicable when using a temperature sensor.

### **Auxiliary settings**

- Some of these settings are custom and applicable only for certain controllers.
- Reports widget. You can create a report and export to CSV format.
- Total engine runtime and last duration runtime.
- Weekday selectable start stop timer, time zone setting. This timer will run even after the controller has lost its internet connection. It is equipped with an onboard hardware RTC to keep time and stores the last known time configuration within its memory.

**Note:** CR2 button cell required for real time clock storage. The controller is not shipped with onboard battery due to shipping regulations.

## **OPERATION**

### **Power on the controller**

After powering on, the controller will connect to the preconfigured Wi-Fi settings and establish a connection with the app.

### **Initial AutoGen app settings**

- If monitoring a battery bank, set the Low and High voltage settings as required. Adjust battery bank calibration slider if required.
- When no battery bank will be monitored, set the Low setting to 0v and High to 12v.
- Select the appropriate running signal.
- Make sure at this stage that the LCD is displaying Standby Mode.

### **Operating modes description**

- **Standby Mode** - During this mode, the generator is on standby and is monitoring or waiting for a trigger. This could be a remote start request from app, battery bank has fallen below preset threshold or triggered via 2 Wire external source. Whichever comes first.
- **Starting Mode** - Engine cranking with or without choke applied. 3 startup attempts with pauses between retries. If all 3 attempts fail, it will enter Error State.
- **Error Notify Mode** - If in this state, you will be sent an error notification via e-mail. Pressing the stop button will exit the error state.
- **Load Check Mode** – If the bank voltage falls below the preset level, it will enter load check for 30 seconds. If the voltage is still low after this period, then the generator will start.
- **Quiet Active Mode** – When using the quiet timer, the generator is not allowed to start.
- **2 Wire Start Mode** – This state is activated if pin# 12 is reading 12v during Standby.
- **2 Wire Running Mode** – This state is monitoring pin# 12 to shutdown the generator. If the generator has shutdown due to lack of fuel, mechanical issue etc, while pin# 12 is still reading 12v, it will enter 2 Wire Error State.
- **2 Wire Error Mode** - If in this state, you will be sent an error notification via e-mail. Pin# 12 must read 0v and pressing the stop button will exit the error state.

## Starting generator remotely

Whenever we want to start the generator remotely via app, we need to make sure that it is always in standby mode.

Pressing start will initiate the startup sequence. It will go through three startup attempts.

## Stopping generator remotely

At any point in time, we can stop the generator by pressing the stop button via app.

However, if the controller is working in 2 Wire Running Mode, after shutdown it will enter 2 Wire Error State as pin# 12 is still active.



## **Automated start up and shut down**

When the controller is powered, it remains in Standby Mode.

During this state, the generator is on standby and is monitoring or waiting for a trigger. This could be a remote start request from app, battery bank has fallen below preset threshold or triggered via 2 Wire external source.

Whichever comes first.

## **Externally triggered start up and shut down**

When the controller is in Standby Mode and senses a +12vdc signal on pin#12, it will initiate a 2 Wire Startup sequence, then enters 2 Wire Running Mode. When the signal becomes 0v(open circuit) it will shut down the generator.

## **Faults reference codes**

- **Error state 3** – If generator was running and it shutdown prematurely without receiving a shutdown request, it will enter this state.
- **Error state 4** - After state 3 it will send an e-mail notification.
- **Error state 16** - If generator was running in 2 Wire Mode and it shutdown prematurely and pin#12 is still active, it will enter this state.
- **Error state 17** – After state 16 it will send an e-mail notification.

## **Warning indicators and notifications**

Whenever any of the above states, the error LED in app will illuminate and an e-mail notification will be sent. After inspection you can press stop to remove the error state.

## **SPECIFICATIONS**

### **Power input**

The controller must be powered by 12vdc. Minimum is 10vdc and maximum is 15vdc.

### **Generator running signal input**

Pin#6(L) and pin#7(N) is an AC sensing circuit from 0-240vac

Pin# 11 is a DC sensing input from 0-70vdc

## **Relay outputs**

Pin#5 Auxiliary relay or Choke Linear Actuator trigger.

Pin#8 Stop relay

Pin#9 Start relay

All of the above outputs internally pull to ground when active.

Maximum rating is 1 amp.

## **Battery bank sensing input**

Pin# 10 is a DC sensing input from 0-70vdc

## **TROUBLESHOOTING**

### **Relay connections**

A relay is an electrically operated switch. It consists of a set of input terminals for a single or multiple control signals and a set of operating contact terminals. The switch may have any number of contacts in multiple contact forms such as make contacts break contacts or combinations thereof.

Relays are used where it is necessary to control a circuit by an independent low power signal or where several circuits must be controlled by 1 signal.

The input terminals 85 and 86 as depicted in the wiring diagram are the relay coil contacts. These are controlled by AutoGen.

When the coil is powered, the normally open contact(NO 87) will close to the common contact(COM 30). When the coil is not powered, the normally open contact will open, breaking the circuit.

The relay coil and switch contacts are 2 isolated circuits.

### **Generator running signal**

This signal is crucial for the correct operation of AutoGen controllers.

When the starter motor is cranking the engine, the controller needs to sense a running signal to detach the starter motor from overrun.

If pin#11 is used, the signal must be above AutoGen X – running signal adjustment to trigger engine running status. Recommended setting is 10vdc

If pin#6(L) and pin#7(N) are used, the signal must be above AutoGen X - running signal adjustment, recommended 90vac(for 110vac) or 200vac(for 220vac), to trigger engine running status.

**Note:** Pin#11 should be connected to positive terminal of 12vdc charging port of generator if available. It should ONLY read 12vdc when engine is running. If a signal is not read in app when engine is running, check the ports with a multimeter. You may need to connect the negative side of port to pin#2 Common Ground.

## **Internet connectivity**

If the controller loses Internet connectivity, you will not be able to monitor and control via app. The status LED should be Green colour when connected to the internet and Red if not.

You can either try rebooting the controller and/or the Wi-Fi router.

If the issue still persists you can contact our support team.

## **AutoGen app connectivity**

To be able to monitor or control your generator via app, it is essential to have a mobile data connection or Wi-Fi connection.

The QR code directly links to your specific controller. If there is a red indicator in the top right hand corner of your app this means that the controller is either not connected to the Internet, or in some cases your ISP is blocking port 80.

## **Appendix I: OTA(over the air) updates**

If you have been instructed to perform an ota update, make sure that the controller is powered and has internet access. When status led is Green, press and hold the Boot button for 3 seconds then release. When depressing the boot button, the status led will be Red colour and with a breathing pattern.

Once released it will check for an available update. If it blinks red 3 times, no update is available. If it blinks red, blue a few times, an update is available

and it will download/ install the update. This can take several minutes. Never disconnect from power or press the reset button during this process.

## **Appendix II: Voltage input calibrations**

Under Auxilliary Settings in AutoGen app, you will find Calibrate numeric widgets for pins#10,11,12 and AC(L and N).

The way to perform these calibration settings are as follows:

Connect pin#10 to your battery bank or starter battery.

Use a multimeter to measure this voltage.

If the voltage being sent as an example is 12.63v, enter the value once. The controller will then store that value to make calculations against any voltage drop at that given time.

Perform the same for the remaining pins.

Keep note to select the correct **running signal** and **AC running signal adjustment** values first under AutoGen settings for pin#11 calibrations and AC calibration.

### Example:

If you will be using the generators 110vac output as the generator running signal, select **12vac out or 110/220vac out – L and N** under AutoGen settings then enter 90 under the **AC running signal input adjustment**

Start the generator manually to feed this voltage to pins L and N, measure the voltage with a multimeter and enter the measured voltage in **AC Calibrate** widget under Auxilliary settings.